

Disaster Management in Crisis Situation

Dinesh Misale¹, SurajPawar², SanketKasurde³, ShubhamLimkar⁴

U.G. Student, Department of Computer Engineering, Trinity Academy of Engineering, Kondhwa, Pune, India¹

U.G. Student, Department of Computer Engineering, Trinity Academy of Engineering, Kondhwa, Pune, India²

U.G. Student, Department of Computer Engineering, Trinity Academy of Engineering, Kondhwa, Pune, India³

U.G. Student, Department of Computer Engineering, Trinity Academy of Engineering, Kondhwa, Pune, India⁴

ABSTRACT: Charity and helping others is a act of kindness, where a person who has financially more than enough of what he or she needs to be contributes a part of his or her surplus income for the fulfilment of the needs of those who are less capable. Due to Crisis situation or any Natural Calamities such as Covid-19, Tsunami, Landslide, Earthquake etc. various structures get disturbed and lead to financial damage, property damage and loss of life. In order to Covid-19 has/will hit hard to poor as well as rich i.e. economically, mentally and physically. Also, People or donor who want to help to find them is very hard task, to overcome this issue there is need to develop/construct a social helping web application regarding to crisis situation or disaster situation. In which people can volunteer and reach out to poor people to help them with necessary resources like foods, clothes etc.

We will be collecting data by two modes one is from user and second will be a MQTT publisher which will act as an IoT devices and send data from dataset on a specified time interval. With the help of this data it will generate an alert. With the help of alert will get to know where the disaster has been occurred. Also, user can provide information about the disaster by filling the form on portal. After providing details correctly help will be provided by volunteers. This web application / website is developed by using HTML, CSS, React.js, Node.js, Express.js, MongoDB. This paper main goal is to develop a web app for disaster management. This system will be very useful in critical or disastrous situation.

KEYWORDS: Disasters, Disaster Management, Charity, Web Design, Web Development.

I. INTRODUCTION

Disaster Management is the organization and management of the assets or the resources and responsibilities for dealing with all humanitarian aspects of difficult, accident or any emergencies, in certain aware-ness, response and recovery in-order to reduce the impact of calamities. Post Disaster management aims to reduce, or avoid the possible losses from threats, assure prompt and appropriate assistance to victims of disaster and attain fast and effective recovery. As disasters are dangerous to human life, an effective approach or measure or any other alert system must be implemented to advise individual in the beginning phase towards security precautions could be considered to avoid any disaster or calamities.

In existing system, the outcomes consist less specificity, less sensitivity. The existing system provides government data set and disaster dataset, also provides news. It is used for public welfare and efficient management of disaster. The existing web application include all the detail about helplines and government bodies to be contact in the stage of emergency.

This research is to design and develop a web application or website for post disaster management in any critical situation. Here the main objective of this web application is to provide an emergency response to the people who are going to be affected in disaster or any other calamities. Following are the main objectives: -

- To provide food, clothes or related resources through volunteer in disaster and crisis situation.
- To provide a platform where people can help each other.
- To obtain the web-application where admin can update news of latest disaster or calamities.
- People will find the correct and easy way or platform to help the short-handed people.
- To provide a quick response if any disaster occurs.

II. LITERATURE SURVEY

As per [1] it is described about vulnerabilities and security of web application. Web applications are active websites which are piece of server-based programs helping user interaction and various other functionalities. Web Server safety is



thus an important phase for any organisation having web server connectivity with the internet and also to assure customers using their websites, for a secure online portal. In this age of digital revolution, there has been a boom in demand of web developers who can create user friendly web platforms such as mobile applications, web applications. The user base for online website is on a rise too. Here they have provided a comprehensive knowledge of web application security and vulnerabilities present in it. It also covers various phase of security pattern which are extensively used in the field of academics, e-commerce and current scenario of various tools like operating system, databases and mobile applications.

In [2] it is explained about the reliable web-api's in the fight against covid-19 infodemia. Infodemia is an overload of data about a problem, usually false and unverified. Here it is suggested that, the problem of infodemia created by declaring a COVID-19 pandemic is considered. A list of Web services has been formed that provide dependable pandemic data from relevant and suitable sources, and as such, in the fight against the COVID-19 infodemia can be used. In addition to global pandemic data, information on individual countries and regions from this service may be requested. The latency of the Web API service COVID-19 data was determined using the `getLatestTotals` function for reading global information. Based on the obtained results, a way of using this Web service in the fight against the COVID-19 infodemia was proposed.

As per [3] implemented a phone application as it highlights the key features on emergency response and disaster management. It reviews the mighty mechanism for aiding the management procedure. They also developed a prototype keeping in mind the various features and disadvantage of the reviewed disaster applications. Based on parameters like reliability, ease of use, timeliness and region accuracy, their app successfully meets the performance criteria. Here existing proposed solutions for disaster management are reviewed. Next, a prototype is suggest for disaster management by considering the advantages and restriction of the reviewed systems along with the success factors for disaster management. Further, it is concluded by providing future research directions including the integration of application with government authorities, hospitals and other rescue teams.

In [4] it is described how to focus on the efficient collection of disaster-related information on Twitter or other social media. In previous studies, they have proposed a method to collect tweets posted immediately after retweeting a news post about a disaster or any other calamities. In addition, to automatically collect or store disaster-related data by focusing on tweets posted immediately after retweeting the news post, they have proposed a keyword-based property to differentiate whether the tweets are relevant to the disaster. They have develop the prototype of a web application for storing data relevant to the news posts, with the aim of developing a web application, which will enable content providers, local government staff, and general users to store disaster-related tweets with ease.

As per [5] it is explained about web-based application that is stored in HAPS (High Altitude Platform Station) to facilitate communication or conveying and eviction of disaster in rural areas called Tele HAPS. Tele Haps has three main components namely Tele Chat, Tele Data and Tele Camera. Tele Chat is a service that serve to send and retrieve text messages, images or pictures and videos that are running locally. Tele Data is a real time disaster collection component and the outcomes of the data stored are presented in tables format. While Tele Camera is a camera access service component at HAPS to facilitate the awareness of rural region and affected by the disaster. The Tele HAPS application is built using HTML, CSS, PHP and JavaScript programming languages, using Sublime software, using Apache as a web server, and also using MySQL as a database

As per [6] it ensures web application security testing framework method that mainly focuses on web application/ website security to find weaknesses in a website. It aims to ensure the security and safety of websites in form checklists. It has the 10 most dangerous types of website vulnerabilities such as injection, broken authentication, sensitive data exposure, Extensible Mark-up Language external entities, corrupted access control, security misconfiguration, cross-site scripting, unreliable deserialization, segment exploitation with known weaknesses, and lack of logging and checking.

As per [7] it ensures the purpose of the research is to study and explore the importance of hospitals in natural disaster calamities and events and to identify the impacts on the hospitals in natural disaster events. A disaster is an not predicted event, which can overwhelm the capacity of the affected people to manage its effect. Many people are periodically exposed to natural disasters calamities in their life, and most disasters, or more correctly hazards that lead to disasters, cannot be prevented. However, their effects can be reduced.

III. PROPOSED METHODOLOGY

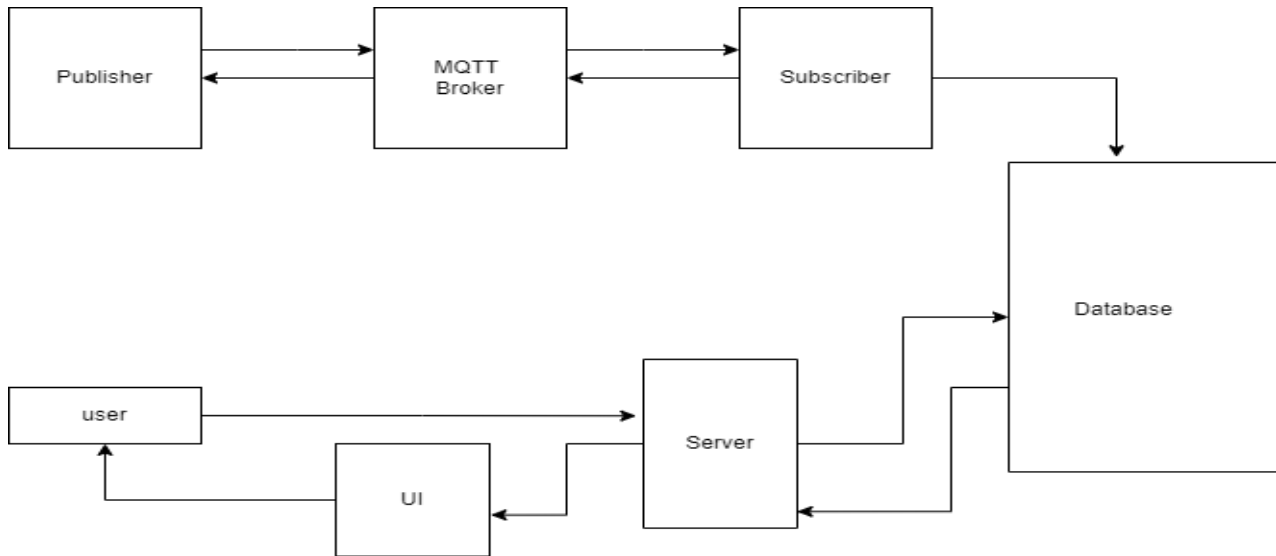

Fig 1: Architecture Diagram of Disaster Management In Crisis Situation.

The above diagram shows the system flow of this project. The web application is developed with the vision of helping people in post disaster situation and to achieve this goal we will be using a MQTT publisher which will act as an IoT devices and send data from dataset on a specified time interval after using this data an alert will be generated at server side and will be stored and examine by the admin to check whether the alert generated is valid or not. After confirming the alert generated will assign volunteers to relevant areas so that they could reach out to help people by distributing foods and necessary goods to them. Besides from the MQTT publisher generated alert the admin can also create alert and the following process will be carried out.

Administration System:-

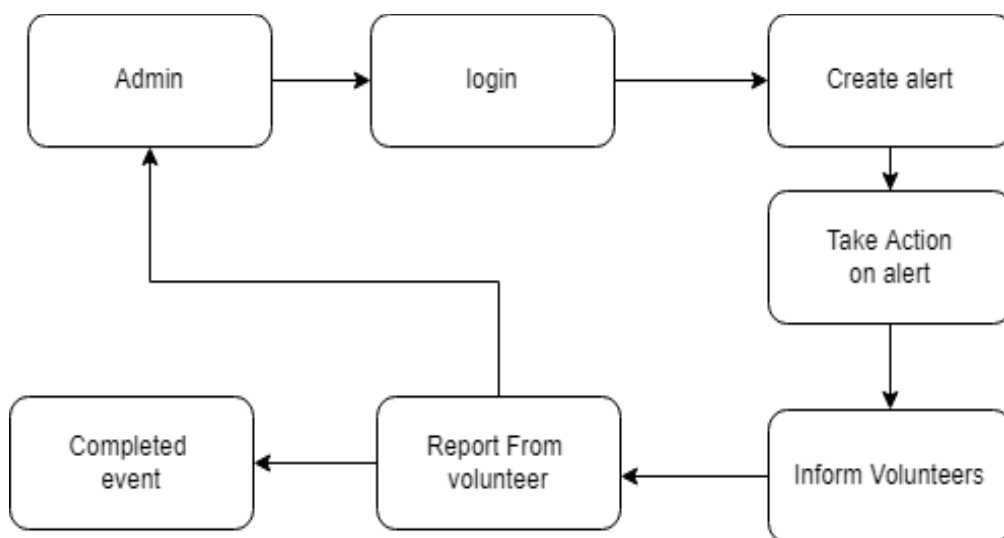

Fig 2:- Administration System.

The above diagram shows the administrationsystem of this project. Here the admin creates the alert and assign the alert to volunteers with the help of data provided by users and mqtt publisher. Admin can add the volunteers where volunteers can see the alert events and also get informed with the help of mail.

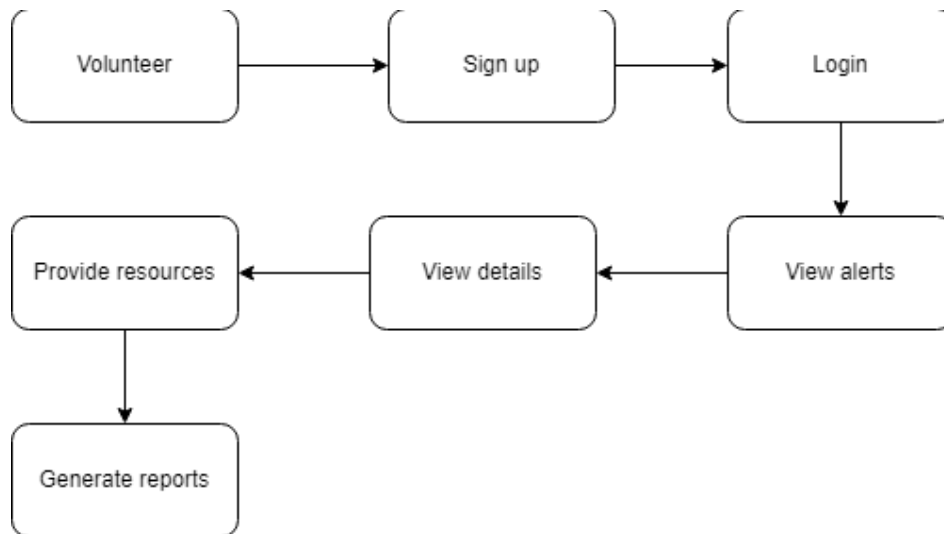
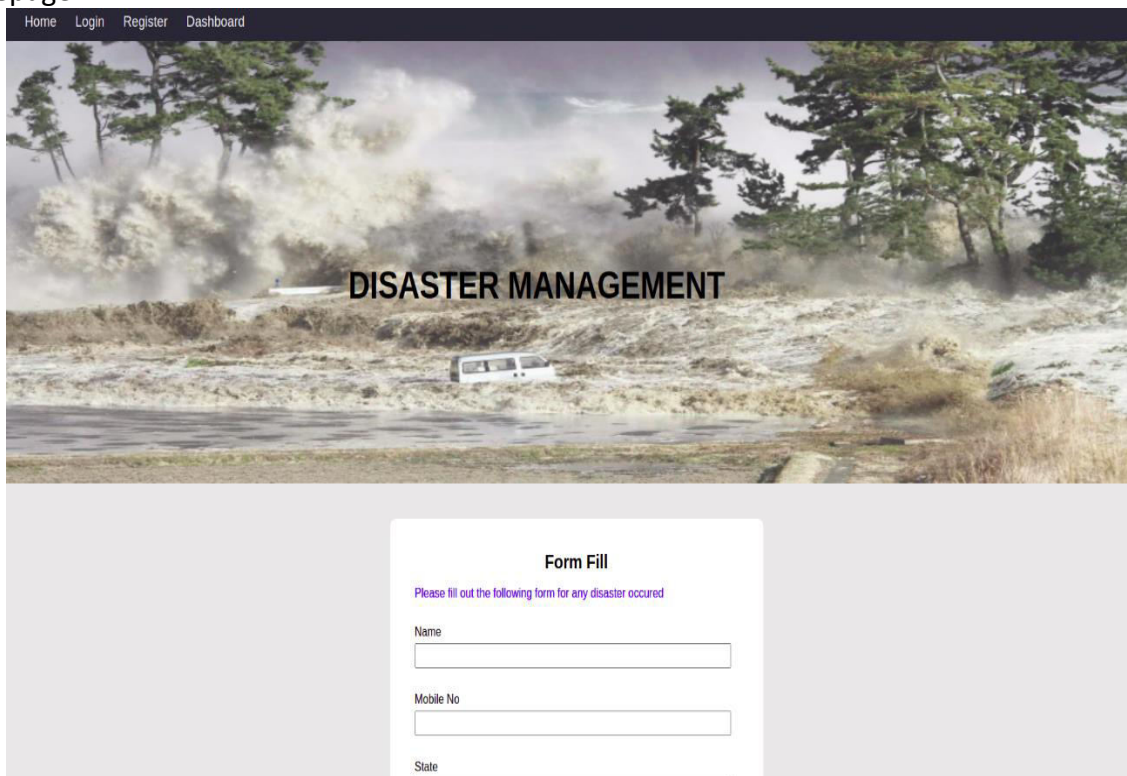

Fig 3:- Technical Setup

1. Volunteer Registration/Sign up
2. Login[valid id is must]
3. Task and events assigned
4. Details about events
5. Feedback options

IV. RESULTS

- Homepage:-





- User Request Form Fill :

The screenshot shows a web interface with a navigation bar at the top containing 'Home', 'Login', 'Register', and 'Dashboard'. The main content area is titled 'Form Fill' and includes the instruction 'Please fill out the following form for any disaster occurred'. The form contains the following fields: Name, Mobile No, State, City, Type Of Disaster, Area/Address, Latitude, Longitude, and Population Of People. A 'Submit' button is located at the bottom of the form.

- Volunteer Registration:

The screenshot displays a 'Register As Volunteer' form. It features four input fields: 'Enter Your Email', 'Choose Your User Name', 'Enter Your Password', and 'Confirm Your Password'. A blue 'Register' button is positioned below the password fields. At the bottom left, there is a link that says 'Already have an account login'. To the right of the form is an illustration of a person interacting with a large smartphone, with gears and a leaf symbol nearby.



- Disaster Details:-

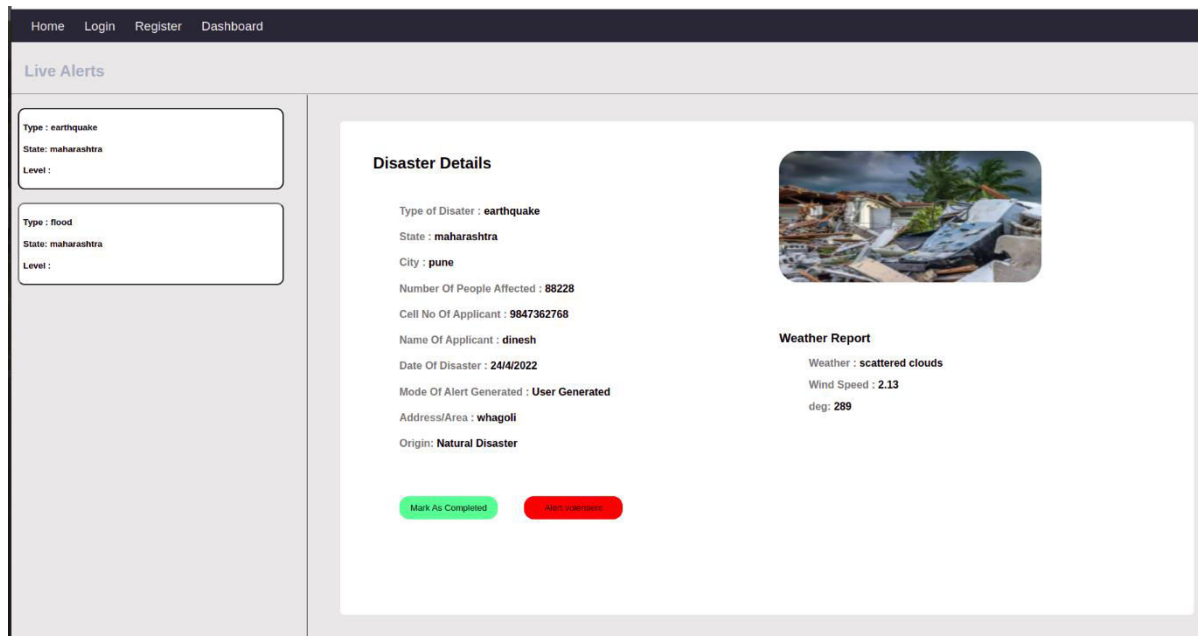

V. CONCLUSION

This project deals in-order to provide the emergency response in disaster or any other kind of crisis situation. This web application will be collecting data by two modes one is from user and second will be a mqtt publisher which will act as an IoT device and send data from dataset on a specified time interval. With the use of this application we will be able to help peoples who are suffering from any kind of disaster and crisis situation by providing them with foods and necessary goods.

REFERENCES

- [1] DivyaniYadav, Deeksha Gupta, Dhanajay Singh, Devendra Kumar, Upasana Sharma, "Vulnerabilities and Security of Web Applications", International Conference on Computing Communication and Automation, 2018.
- [2] Zoran S. Velickovic, Marko Z. Velickovic, Zoran N. Milivojevic, "Application o f a Reliable Web API's in the Fight Against COVID-19 Infodemia", International Conference on Information Technology, 2021.
- [3] VidhiMody, VrushtiMody, Soham Parekh, "Distress – An Application for Emergency Response and Disaster Management", International Conference on Smart Electronics and Communication, 2020.
- [4] Keisuke Utsu, Ayami Manaka, Koki Nakafuri, Osamu Uchida, "Web Application Prototype for Collecting Disasterrelated Information Focusing on Tweets Immediately after Retweeting News Posts", 2017.
- [5] Ahmad FauziIskandar, Iskandar, TutunJuhana, Hendrawan, "Web-Based Application Design Rn HAPS Ior Rural and Disaster Affected Areas", 2019.
- [6] MuhamadAgreindraHelmiawan, EsaFirmansyah, IrfanFadil, YanvanSofivan, FathoniMahardika, AgunGuntara, "Analysis Of Web Security Using Open Web Application Security"International Conference on Cyber and IT Service Management(CITSM), 2020.
- [7] Salamati Nia, S. P., &Kulatunga, U. "The importance of disaster management and impact of natural disasters on hospitals", 2017.
- [8] Amit Sarkar, Joy Bose, "A Web Service to Generate Intelligent Previews of Web Links", IEEE International Conference on Web Services, 2018.
- [9] Shukla S. S., Disaster Management:"". International Journal of Scientific Engineering and Research (IJSER), Managing the Risk of Environmental Calamity 2013.
- [10]P. P. Jayaraman, "Internet of Things platform for Smart farming: experiences and lessons learnt," Sensors (Switzerland), vol. 16, no. 11, pp. 1–17, 2016.